

# STR Periscope **STR602**

*Multiple Gate Locations  
Adjustable Humidity  
MTP and Limbro Compatible*



STR602 Series

## STR 602

The STR602 is ideal for protein crystallization work because the carousel can be stationary with the Star concept allowing the inner rotation the only moving part, reducing vibration and movement of the samples.

While allowing full remote access on handling and climate functions, you still are able to manually access to cassettes located in the back of the incubation chamber the integrated carousel maybe positioned automatically or be rotated manually.

By using the Star concept it allows maximum capacity and configuration. The delivery gate can be on the rear right/left or in rear center. This allows the unit to be positioned in the desired location

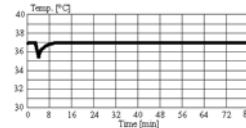

Access through the small robotic gate

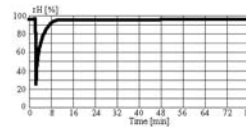

Access through full-sized user door

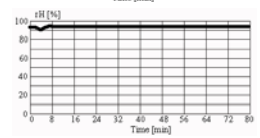
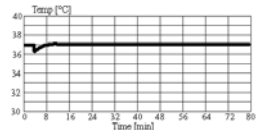

### Climate Options

Type	Temperature	Humidity	Description	Order Nr.
STR602-IC	33..50°C (70°C)	max. 95%	Incubator	9141 01 79
STR602-HC <sup>1)</sup>	04..25°C	max. 90%	Humid Cooler	9141 01 80
STR602-DC2 <sup>1) 3)</sup>	04..25°C	04..50%	Dry Storage	9141 02 27
STR602-HR <sup>1)</sup>	04..50°C (70°C)	90..95%	Humid Wide Range	9141 01 81
STR602-DR <sup>1) 3)</sup>	04..50°C	02..80%	Dry Wide Range	9141 02 12
STR602-AR <sup>2)</sup>	04..50°C	20..90%	Humidity Controlled	9141 02 26
STR602-DF <sup>1)</sup>	-20..0°C <sup>4)</sup>	02..45%	Deep Freezer	9141 01 83
STR602-NC	-	-	No Climate	9141 02 30

1) Humidity depends on temperature setting / 2) Humidity Adjustable / 3) Adjustable dehumidification / 4) up to +20°C on request

### Options

	Order Nr.	Gassing Option	Order Nr.
High temperature 70°C capability	9122 06 06	Fast CO2 Gassing Option	9118 11 12
Bar Code Reader Option	9122 06 03	Fast N2 Gassing Option	9118 11 13
Plate Presence Sensor	9121 00 62	Fast O2 Gassing Option	9118 11 14
Disposal Tips upgrade kit up to 100 mm height	9118 12 23	Additional CO2 Gassing Option	9118 11 07
Fast access for time critical applications	9122 06 04	Additional N2 Gassing Option	9118 11 11
N-Way Decontamination	9122 05 28	Additional O2 Gassing Option	9118 11 08
Liconel self decontaminating incubator chamber	9141 01 78		
Proteomics additional inner rotation for plate transport	9141 01 85		
Option Linbro Plate Handling	9141 01 86		
Side Gate on left side wall	9141 01 87		
Side Gate on right side wall	9141 01 88		
Linear Shaker, Amplitude 1-100mm, 12-300 rpm	9141 02 19		
UCI Universal Communication Interface	9118 11 17		
Steam Injection	9118 11 16		

Like all members of the StoreX Star family the STR602 can be equipped with a large number of further options and a wide selection of useful accessories. For details please visit [www.liconic.com](http://www.liconic.com).

### Dimensions

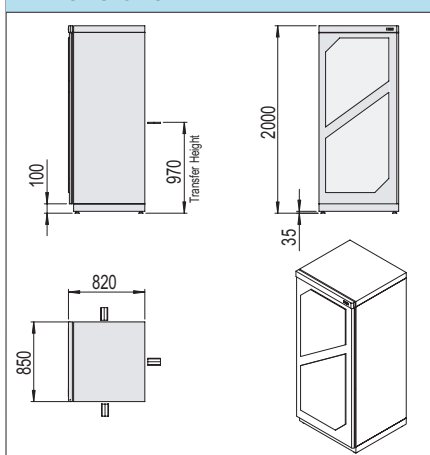

### Capacity

Plate Type	Plate Height	Plate capacity of unit
NTP (Nanotiter Plates)	5 mm	1100
	11 mm	740
MTP (Microtiter Plates)	12 mm	700
	17 mm	560
	22 mm	460
	23 mm	440
DWP (Deep Well Plates)	24 mm	420
	27 mm	380
	44 mm	240
	53 mm	200
DiTi200	66 mm	160
DiTi1000	104 mm	100