



 **LiCONiC**
INSTRUMENTS

-80°C
-20°C
+4°C

STT
Series

BiO.Li.X!

STT Series - Automated Bio-Libraries

The STT series provides an entry point for operations that are adopting the benefits of automated storage, such as greater sample safety, process throughput, space and power efficiency, and data integrity.

As the use and importance of biological samples continue to grow in the life sciences, Biobanking encompasses an ever broader range of user and process needs. Automation is a key contributor to solving many challenges in managing these samples. For over 25 years, LiCONiC has led the way for automated sample handling in climate controlled enclosures. With the STT series of BiOLiX! Storage Systems, LiCONiC provides a fully automated sample storage solution specialized for applications that have limited space, smaller sample collections, and/or specialized process requirements such as dedicated workstations for blood processing, nucleic acid, protein, and bacterial plasmid work.

Main Features

- Ultra low temperature
- Quick installation - plug and play
- Fully automated sample picking & tracking
- Compatible with all SBS rack formatted tubes and vials
- Exceptional frost control
- External transfer station
- Easy to service
- LIMS and robotic workcell integration

STT Series Product Overview

High sample density in smallest footprint for storage of:

- RNA / DNA
- Bacteria
- Proteins
- Serum / plasma / buffy coat
- Whole blood
- Small molecule compounds

Shares same features with larger systems:

- No compromise of functionality
- Ideal for stand alone function or integrated workcell applications



STT1k5-ULT

The STT series provides an entry point for customers to install a validated process in handling of bio-samples with a fully automated biobank. All units will be delivered with the intuitive Plate Explorer control software and pre-configured PC. The design allows integration to robotic platforms and LIMS databases.



STT1k0-DF

The STT series is the most compact of LiCONiC's fully featured, low temperature automated storage line. These stores are fully factory assembled for plug and play installation, significantly reducing delivery times and installation complexity. These stores share all the features and functions of the larger STC series stores but in the most efficient space configuration.



STT3k0-DF

STT Capacities

BiOLiX! STT Series examples			STT1k0-DF		STT3k0-DF		STT1k5-ULT	
Labware	Plate height	Pitch	Levels	Samples	Levels	Samples	Levels	Samples
FluidX 0.3 ml Screw Cap	19.1 mm	25 mm	50	96'000	44	253'440	64	122'880
Micronic 0.5 ml Screw Cap	28.5 mm	35 mm	35	67'200	31	178'560	45	86'400
LVL LX1000	45.6 mm	52 mm	24	46'080	21	120'960	30	57'600
Thermo Matrix 1.0ml Screw Cap	54.6 mm	61 mm	20	38'400	18	103'680	26	49'920
Greiner Bio One 2 ml	48.0 mm	54 mm	23	22'080	20	57'600	29	27'840

STT Storage Conditions

Automation in ultra-low temperature requires time-tested, field proven operation. Keeping the climate stable and frost-free in an instrument that is exchanging samples with an external environment requires good design and experience. LiCONiC incorporates our 25 years of field tested automation and environmental control designs to ensure temperature stability, homogeneity, and humidity control across all BiOLiX! systems.

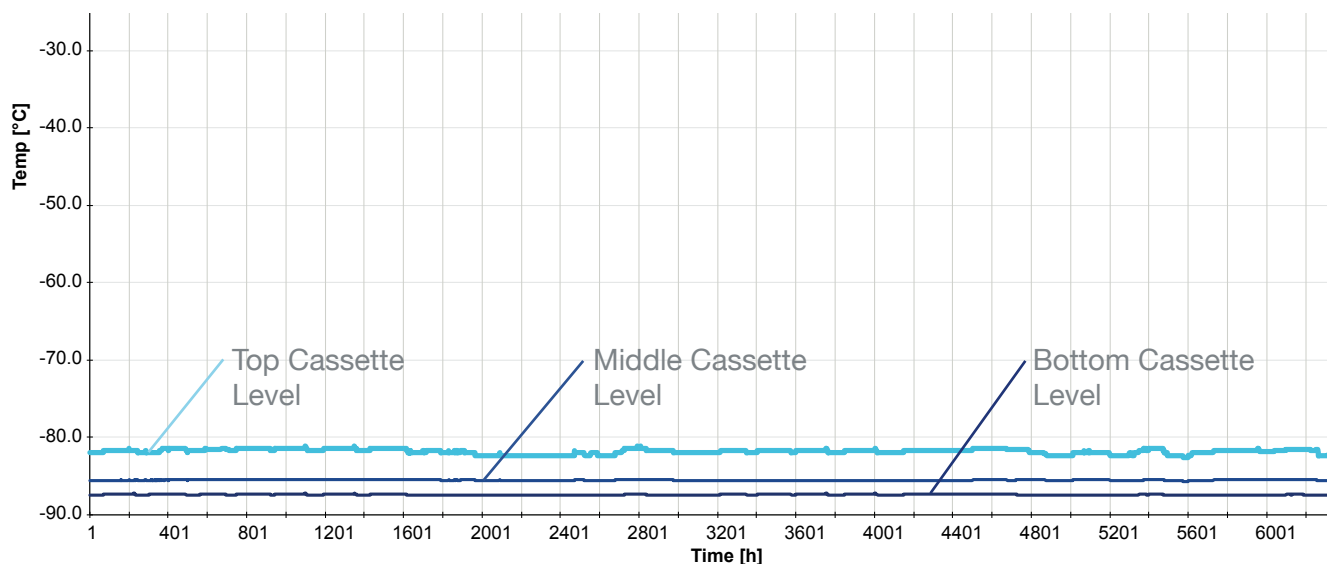

The STT series employs the same features found in larger scale BiOLiX! storage systems, such as vacuum enhanced insulation for sample safety and power efficiency, and a frost prevention design working in hundreds of field installations.

Flexibility

Plug & Play Automated BioLibraries for 50'000 to 150'000 samples capacity. Ideal for work cell applications incorporating fully automated workflow or as a stand-alone work stations. Maximum flexibility, easy rolling from lab to lab.



Intuitive Software

- Graphical Job Creation for Import/Export of Samples
- Easy Search of Samples by Barcode, Name, Data etc.
- Complete Audit Trail
- Automatic Inventory Defragmentation
- Automatic Data Backup
- Integration to LIMS Database
- Remote Support
- Mobile Device Control
- User Access Security

Options & Accessories

- Barcode Reader
- Flexible Labware Support
- Configurable to Room Constraints
- Tablet Interface
- External Database Integration
- Remote Monitoring
- Internal Vision System
- Multi - Tube / Vial Picker
- LN2 - Backup Option
- 2D - BCR Rack Scanner
- Redundant Refrigeration
- Dynamically Configurable Storage Cassettes
- External Interface Station

STT Dimensions

BiO.Li.X!			
STT Dimensions examples			
Type	L= Length	W= Width	H= Height
STT1k0-DF	1280 mm	1238 mm	1987 mm
STT3k0-DF	2000 mm	1435 mm	2090 mm
STT1k5-ULT	2345 mm	1490 mm	2328 mm

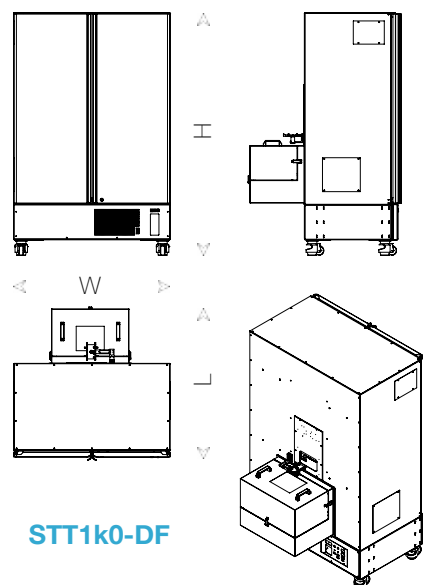
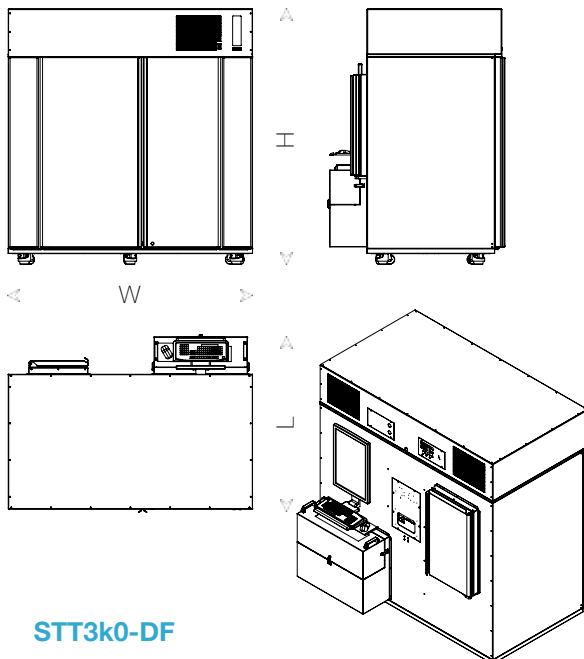

Worldwide Presence

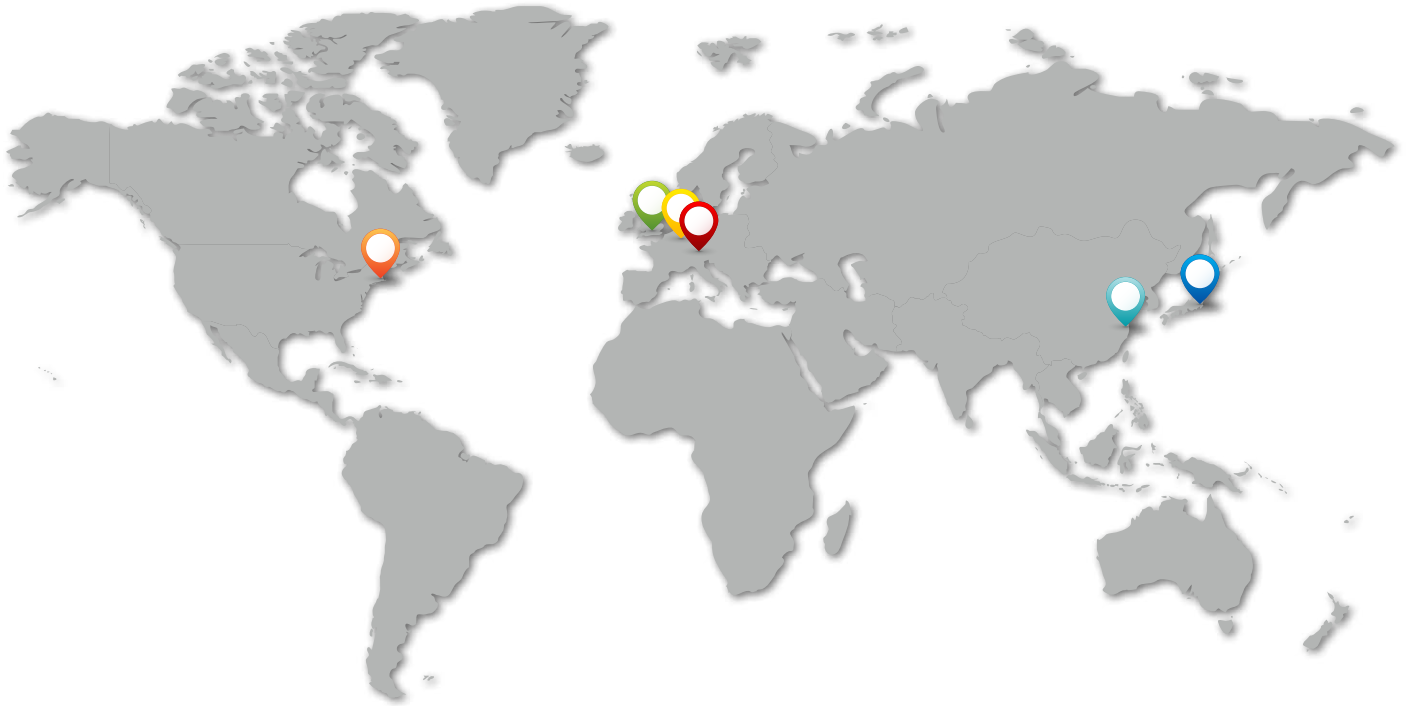

CORPORATE **LiCONiC AG**

LiCONiC AG
Industriestrasse 8-12
9493 Mauren
Principality of Liechtenstein

Phone: +423 37 36 33 9
Fax: +423 37 35 35 9
E-Mail: info@liconic.com
sales@liconic.com
service@liconic.com

LiCONiC Services **Deutschland GmbH**

Bahnhofsplatz 3
D-56410 Montabaur
Germany

Phone: +49 2602 997 4557
Fax: +49 2602 997 4559
E-Mail: info.de@liconic.com
sales.de@liconic.com
service.de@liconic.com

LiCONiC UK Ltd

BioHub
Alderley Park
Macclesfield
Cheshire, SK10 4TG
United Kingdom

Phone: +44 (0) 1618 752 542
+44 (0) 1618 752 543
Fax: +44 (0) 1618 752 540
E-Mail: info.uk@liconic.com
sales.uk@liconic.com
service.uk@liconic.com

LiCONiC US, Inc.

21-F Olympia Ave
Woburn, MA 01801
USA

Phone: +1 (781) 309-3340
Fax: +1 (781) 537-6173
E-Mail: info.usa@liconic.com
sales.usa@liconic.com
service.usa@liconic.com

LiCONiC Japan K.K.

2-2-15 Daiya Bldg 2F
Hamamatsu-cho, Minato-ku
Tokyo Japan 105-0013

Phone: +81 3 6841 0707
E-Mail: info.japan@liconic.com
sales.japan@liconic.com
service.japan@liconic.com

LiCONiC China Co. Ltd

1-B102, No.3891, Jinxiu Rd
Shanghai (201204),
R.P.China

Phone: +86 186-2156-0603
E-Mail: info.china@liconic.com
sales.china@liconic.com
service.china@liconic.com

Asia:

Phone: +1 (760) 522-2455
E-Mail: info.asia@liconic.com
sales.asia@liconic.com
service.asia@liconic.com



Information within this document is subject to be changed without prior notice. For details please contact our applications at info@liconic.com. 20170807



www.liconic.com