

STX Automated Incubators

STX44

*Stand-Alone or Bench-Top
Warm or Cooled Versions
Temperature + Humidity Control*

New

Service Port



StoreX44 Series

Stable and Precise Climate Conditions

STX44

Stable and reproducible climate conditions are the key to success in modern screening applications.

The small StoreX 44 transfer gate guarantees extremely stable and reproducible environmental conditions for your assays. Fastest recovery times allow frequent plate loading and unloading.

Highest accuracy and stability over time is maintained by using sensors monitored by the Swiss Office of Metrology and the Swiss Accreditation Service.

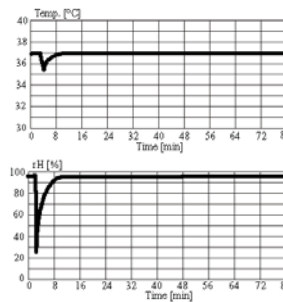

Access through full-sized user door

Access through the small robotic gate

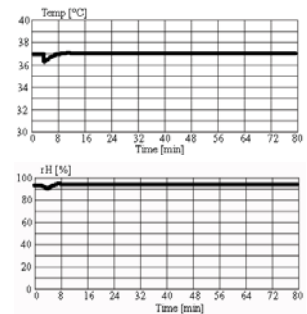

Climate Options					
Type	Temperature	Humidity	Description	Order Nr. STX40 Stand Alone	Order Nr. STX40 Bench Top
STX44-IC	33..50°C (70°C)	max. 95%	Incubator	9118 12 00	9118 07 00
STX44-HC ¹⁾	04..25°C	max. 90%	Humid Cooler	9118 04 00	9118 08 00
STX44-DC2 ^{1) 3)}	04..25°C	04..50%	Dry Storage	9118 12 55	9118 12 56
STX44-HR ¹⁾	04..50°C (70°C)	90..95%	Humid Wide Range	9118 05 00	9118 09 00
STX44-DR ^{1) 3)}	04..50°C	02..50%	Dry Wide Range	9118 05 02	9118 05 03
STX44-AR ^{1) 2)}	04..50°C	10..95%	Humidity Controlled	9118 12 45	9118 12 34
STX44-DF ¹⁾	-20..0°C ⁴⁾	02..45%	Deep Freezer	9118 12 38	9118 12 39
STX44-NC	-	-	No Climate	9118 12 40	9118 12 72

¹⁾ Humidity depends on temperature setting / ²⁾ Humidity Adjustable / ³⁾ Adjustable dehumidification / ⁴⁾ up to +20°C on request

Options

	Order Nr.		Order Nr.	Shaking Options	Order Nr.
High temperature 70°C capability	9118 11 02	Fast CO2	9118 11 12	Orbital, 1mm Ampl., 600rpm	9118 12 24
Bar Code Reader Option	9118 11 03	Fast N2	9118 11 13	Orbital, 1mm Ampl., 1200rpm	9118 12 25
Plate Presence Sensor	9121 00 62	Fast O2	9118 11 14	Orbital, 3mm Ampl., 600rpm	9118 12 41
Fast access for time critical applications	9111 10 00	Additional CO2	9118 11 07	Orbital, 6mm Ampl., 400rpm	9118 12 42
Deep well upgrade kit	9118 12 22	Additional N2	9118 11 11		
Disposal Tips upgrade kit up to 100mm height	9118 12 23	Additional O2	9118 11 08		
N-Way Decontamination	9122 05 28	Steam Injection	9118 11 16		
Liconel self decontaminating incubator chamber	9118 12 43	UCI	9118 11 17		
Easy Clean option	9118 12 21				

Integration

For maximum flexibility the StoreX 44 is available in stand-alone (top transfer gate) or bench-top (bottom transfer gate) versions. The easily access able transfer station and a standard RS232 connection ensure simple integration into an environment.

Dimensions

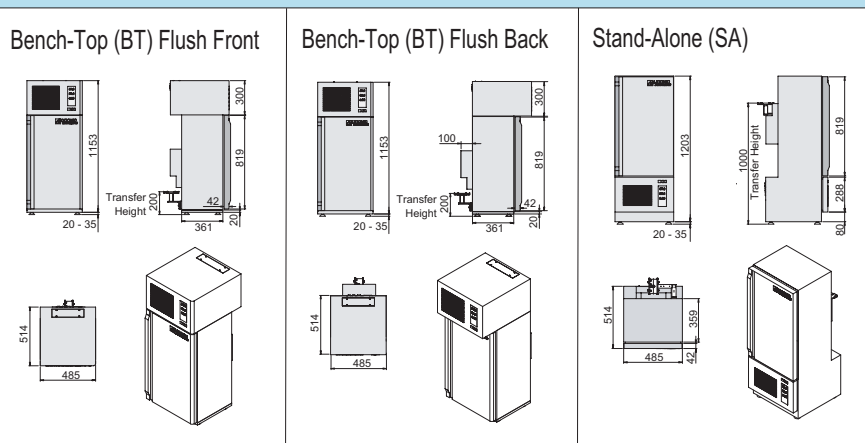

Capacity

Plate Type	Plate Height	Plate capacity of unit
NTP	5 mm	84
	11 mm	56
1536	12 mm	54
	MTP	17 mm
	22 mm	34
	23 mm	34
	24 mm	34
	27 mm	30
DWP	44 mm	20
	53 mm	16
DITi200	66 mm	14
	DITi1000	104 mm